



SUBMITTAL DATA

UNIX Ultra 18 Seer 18KBTU

Model: TUD18-R32AHEDU & TU18-R32WEDU

Job Name

Location

Date

Purchaser

Engineer

Submitted to

For

Unit Designation

Schedule No.

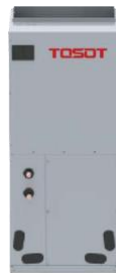

TUD18-R32AHEDU



TU18- R32WEDU

GENERAL FEATURES:

- High Efficiency DC Inverter Technology
- 24VAC Thermostat Compatible
- Zero Lot Line Design
- 8 Speed Fan Motor
- Cooling down to 5°F
- Heating down to -30°F
- Designed for New Construction or Replacement Market
- Coil (Outdoor) Copper Tube/Aluminum Fin with Anti- Corrosion
- Coil Coating (Gold Colored Fin - 1500Hr Salt Spray Rating)
- Coil (Indoor) Copper Tube/Aluminum Fin with Anti- Corrosion
- Coil Coating (Blue Colored Fin - 500Hr Salt Spray Ratin

SPECIFICATIONS & FUNCTIONS:

Air Handler		TUD18-R32AHEDU
Power Supply	V~/Phases/Hz	208~230/1/60
Air Flow Volume	CFM	650
External Static Pressure	W.C.	0.5
External Static Pressure Range	W.C.	0~1
Sound Pressure Level	dB	50
Rated Voltage	V	208/230
Rated Frequency	Hz	60
Phases	-	1
Fuse Current	A	3.15
Circuit Breaker	A	15
Output of Heater	W	5000/10000
MOCP	A	15
Motor Full Load Amp(FLA)	A	1.20
Fan Motor Drive Type	-	Direct-driven
Fan Motor Speed	rpm	940
Fan Motor Power Output	HP	1/2
Evaporator Material	-	Inner groove copper tube-Aluminum fin
Evaporator Face Area	sq.ft	3.45
Evaporator Pipe Diameter	inch	0.28
Evaporator Number of Rows	-	2
Evaporator Tube Pitch×Row Pitch	inch	0.75×0.50
Evaporator Fin Pitch	inch	0.062
Evaporator Number of Circuits	-	10
Evaporator L×H×W	inch	16.3×15×1.5
Evaporator Max. Allowable Pressure	MPa	12.7
Air Filter	-	Metal
Air Filter Size L×W/NO.	inch	19.3×20.3/1
Air Filter Size (Thickness)	inch	0.6
Drainage Connection Size	inch	φ1×0.05
Cooling Temperature Range	°F	64.4~89.6
Heating Temperature Range	°F	50~80.6
Refrigerant	-	R32
Dimension of Outline(W×D×H)	inch	18.11×21.26×43.5
Dimension of Package(L×W×H)	inch	25.98×20.59×46.26
Net Weight	lbs	129
Gross Weight	lbs	144.4

Product Model		TU18-R32WEDU
Power Supply	VAC/Phase/Hz	208~230/1/60
Cooling Capacity	Btu/h	18000
Heating Capacity	Btu/h	18000
EER	(Btu/h)/W	12.5
COP	(Btu/h)/W	12.3
SEER	-	18
HSPF	-	9.0
Air Flow Volume	CFM	2235
Sound Pressure Level	dB(A)	59
MOCP	A	20
MCA	A	19
Compressor Model	-	QXQT-D25zF050C
Compressor Type	-	Inverter Rotary
Compressor Refrigerant Oil Type	-	RM-V68GL
Compressor Refrigerant Oil Charge Volume	L	0.85
Condenser Material	-	Inner Groove Copper Tube-Aluminum Fin
Condenser Face Area	sq.ft	5.38
Condenser Pipe Diameter	inch	φ0.27
Condenser Number of Rows	-	2
Condenser Tube Pitch(a)×Row Pitch(b)	inch	0.87×0.75
Condenser Fin Pitch	inch	0.055
Condenser Fins per Inch (FPI)	-	18
Condenser Number of Circuits	-	4
Condenser L×H×W	inch	39.7×27.7×1.5
Cooling Temperature Range	°F	5~129.2
Heating Temperature Range	°F	-30~75.2
Defrosting Method	-	Automatic Defrosting
Refrigerant Charge-R32	oz	56.4
Dimension of Outline(W×D×H)	inch	36 1/4×14 9/16×29 3/8
Dimension of Package(L×W×H)	inch	42 1/2×19×31 1/2
Net Weight	lbs	133.4
Gross Weight	lbs	143.3
Connection Pipe Length	ft	24.6
Not Additional Gas Connection Pipe Length	ft	31.2
Connection Pipe Gas Additional Charge	oz/ft	0.108
Line Set Size (Liquid - Gas)	inch	1/4"-1/2"
Connection Pipe Max. Distance H×L	ft	49.2×98.4

FAN PERFORMANCE

TUD18-R32AHEDU Static Pressure - Inches W.C.

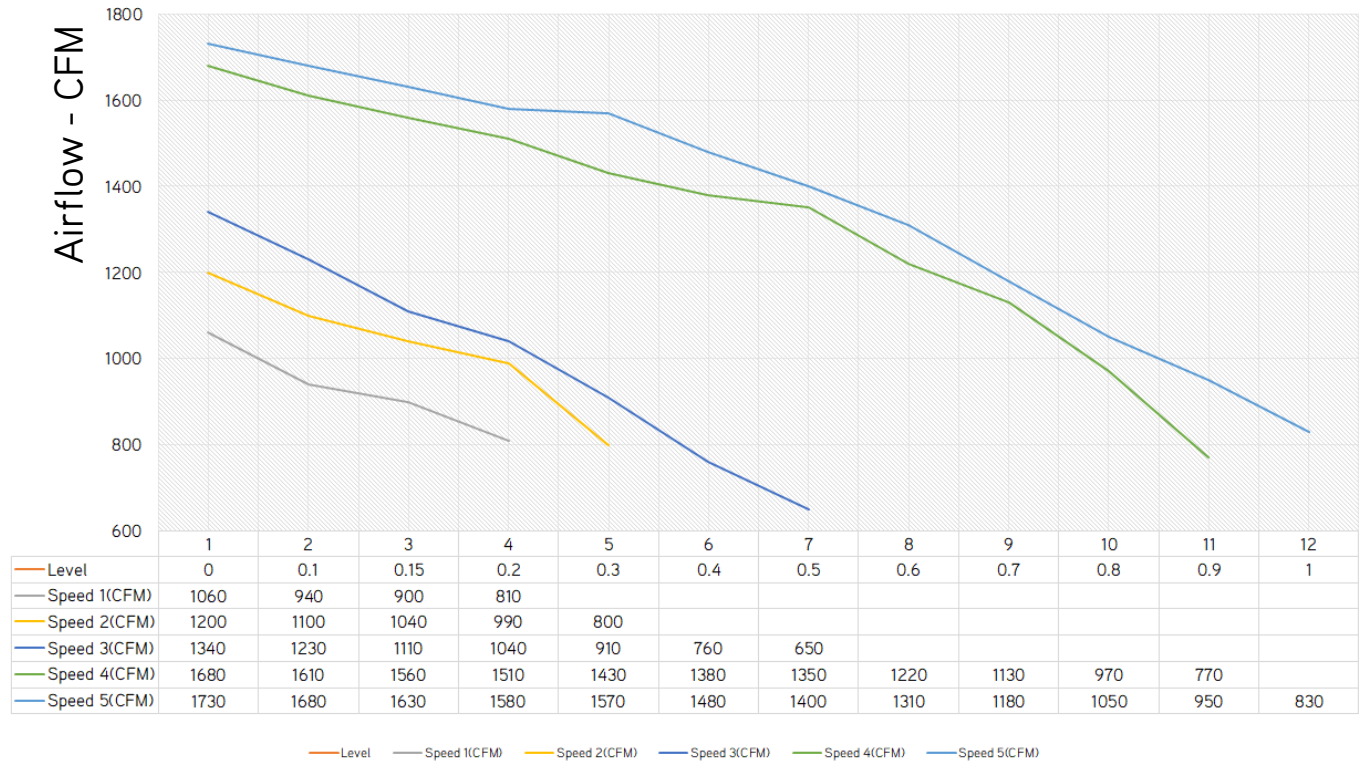

NOTE:

- Above chart CFM ratings are based on dry coil with factory filter installed.
- For wet coil CFM ratings, multiply the CFM by 0.96 correction factor.

DIMENSIONS

INDOOR UNIT

Unit: inch

TUD18-R32AHEDU	
DIMENSIONS	
A	11-5/8
B	16-3/4
H	43-1/2
W	18-1/8
D	21-1/4

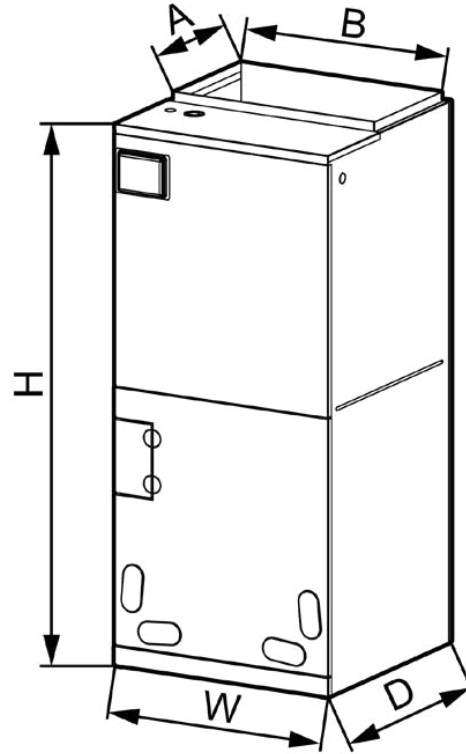

OUTDOOR UNIT

Unit: inch

TU18-R32WEDU	
DIMENSIONS	
A	39-3/8
B	16-13/16
C	29-3/8
D	24
E	15-9/16
F	36-1/4
G	14-9/16

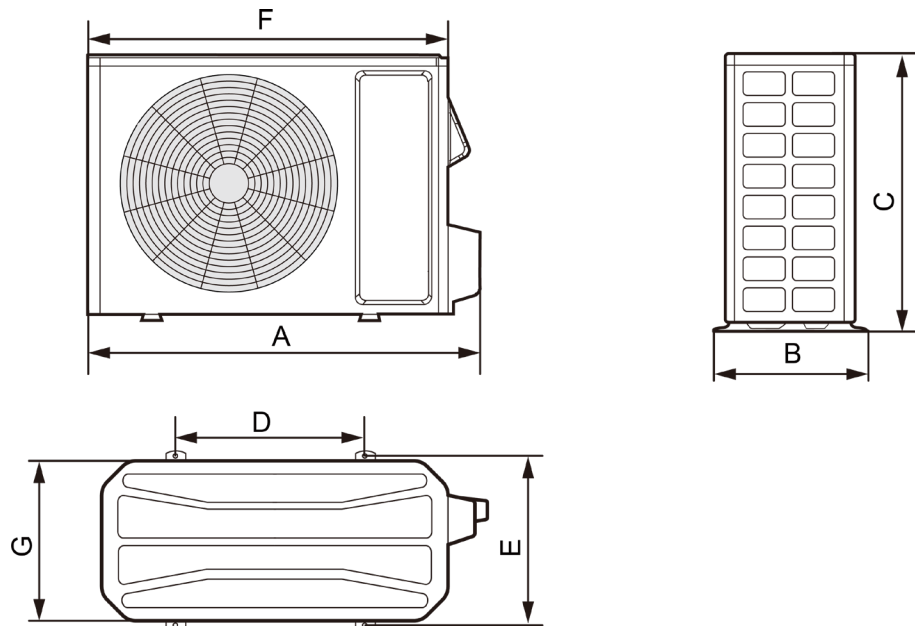

ACCESSORY HEATER AND GENERAL INFORMATION

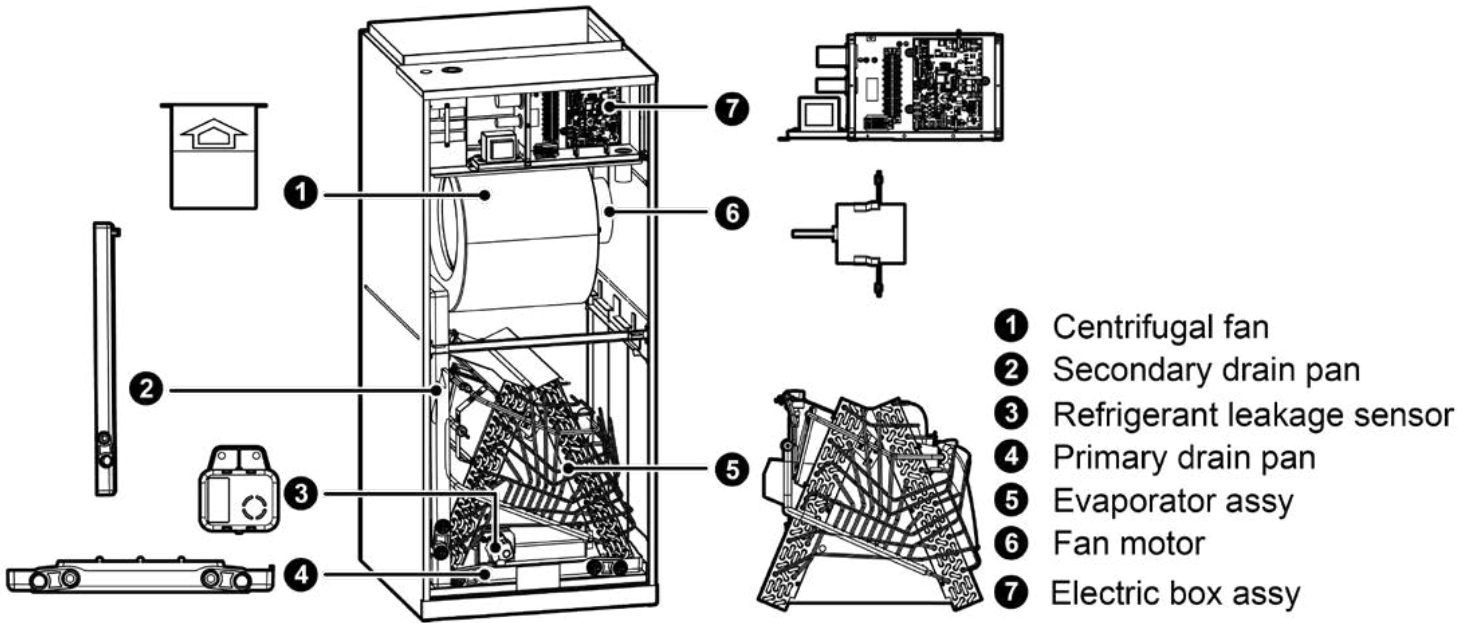

MODEL	Heat Kit Model	Part Number	Electric Heat (kW)		Min. Circuit Ampacity (A)		Max Fuse or Breaker (A)	
			208V	230V	208V	230V	208V	230V
TUD18-R32AHEDU	320004060223	FLEXA2LHTR06	4.5	5.5	32	34.5	35	35

CLEARANCES

INDOOR UNIT

Minimum clearance

FRONT > 24

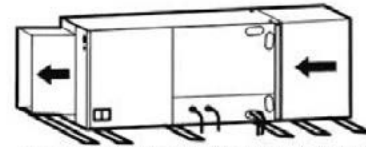
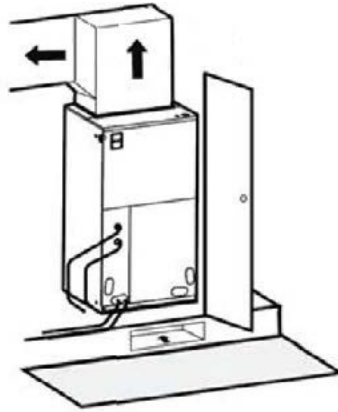

Horizontal Left Configuration - No Modification Needed

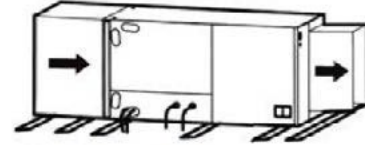

Horizontal Right Configuration - Must Relocate Drain Pan

NOTE:

Allow a minimum of 24" in front of the unit for service clearance. When installing in an area directly over a finished ceiling (such as an attic), an emergency drain pan is required directly under the unit. **See local and state codes for requirements.** When installing this unit in an area that may become wet, elevate the unit with a sturdy, non-porous material. In installations that may lead to physical damage (i.e. a garage) it is advised to install a protective barrier to prevent such damage. This air handler is designed for a complete supply and return ductwork system.

OUTDOOR UNIT

Minimum clearance

NOTE:

Install the Outdoor Unit **2 Inches** Above the Expected Snow Line

1. When one outdoor unit is installed.

A - E	H_b	H_d	H	(in)				
				a	b	c	d	e
B	-	-	-	-	≥ 4	-	-	-
A, B, C	-	-	-	≥ 12	≥ 4	≥ 4	-	-
B, E	-	-	-	-	≥ 4	-	-	≥ 40
A, B, C, E	-	-	-	≥ 12	≥ 6	≥ 6	-	≥ 40
D	-	-	-	-	-	-	≥ 40	-
D, E	-	-	-	-	-	-	≥ 40	≥ 40
B, D	$H_b < H_d$	$H_d < H$	-	≥ 4	-	-	≥ 40	-
	$H_b > H_d$	$H_d > H$	-	≥ 4	-	-	≥ 40	-
B, D, E	$H_b < H_d$	$H_d \leq 1/2H$	-	≥ 10	-	-	≥ 80	≥ 40
	$H_b < H_d$	$1/2H < H_d \leq H$	-	≥ 10	-	-	≥ 80	≥ 40
	$H_b > H_d$	$H_d > H$	Prohibited					
	$H_b > H_d$	$H_d \leq 1/2H$	-	≥ 4	-	-	≥ 80	≥ 40
	$H_b > H_d$	$1/2H < H_d \leq H$	-	≥ 8	-	-	≥ 80	≥ 40
	$H_b > H_d$	$H_d > H$	Prohibited					

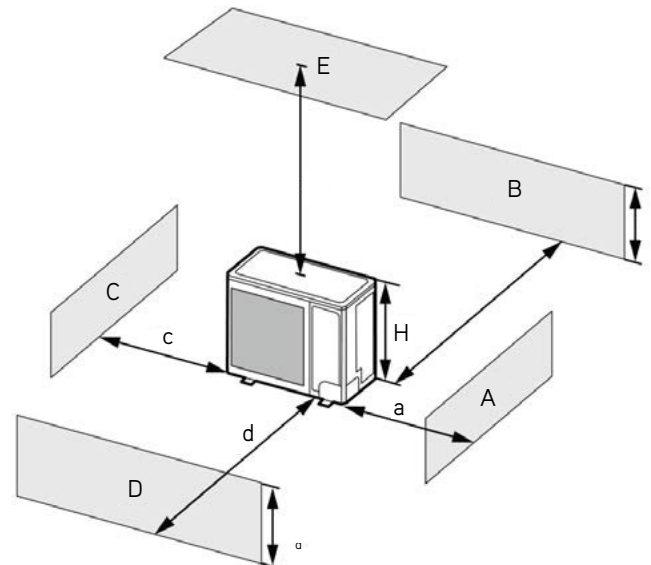

Americo HVAC Supply LLC



Tel: +1 877-298-7191
 Email: info@tosotclima.com
 Website: tosotclima.com

1266 San Luis Obispo Ave.
 Hayward, CA. 94544

CLEARANCES

2. When two or more outdoor units are to be installed side by side.

A - E	H_b H_d H	(in)					
		a	b	c	d	e	
A, B, C	-	≥ 12	≥ 12	≥ 40	-	-	
A, B, C, E	-	≥ 12	≥ 12	≥ 40	-	≥ 40	
D	-	-	-	-	≥ 80	-	
D, E	-	-	-	-	≥ 80	≥ 40	
B, D	$H_b < H_d$	-	≥ 12	-	≥ 80	-	
	$H_d > H$	-	≥ 12	-	≥ 80	-	
B, D, E	$H_b > H_d$	$H_d \leq 1/2H$	-	≥ 10	-	≥ 80	-
		$1/2H < H_d \leq H$	-	≥ 12	-	≥ 100	-
	$H_b < H_d$	$H_b \leq 1/2H$	-	≥ 12	-	≥ 80	≥ 40
		$1/2H < H_b \leq H$	-	≥ 12	-	≥ 100	≥ 40
	$H_b > H$	Prohibited					
$H_b > H_d$	$H_d \leq 1/2H$	-	≥ 10	-	≥ 100	≥ 40	
	$1/2H < H_d \leq H$	-	≥ 12	-	≥ 100	≥ 40	
	$H_d > H$	Prohibited					

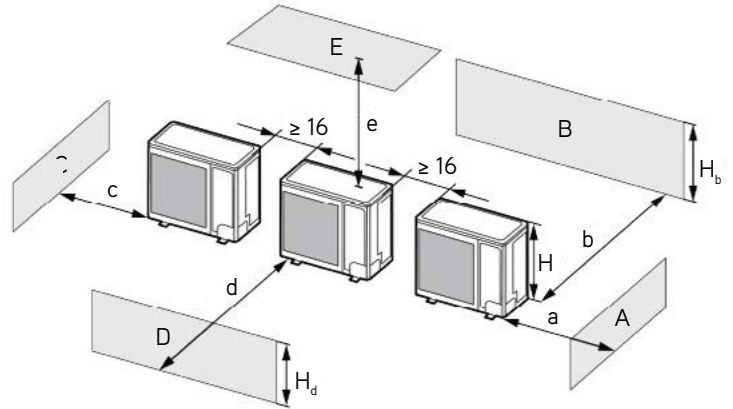

3. When outdoor units are installed in rows.

H_b H_d	(in)
$H_b \leq 1/2H$	$b \leq 10$
$1/2H < H_b \leq H$	$b \leq 12$
$H_b > H_d$	Prohibited

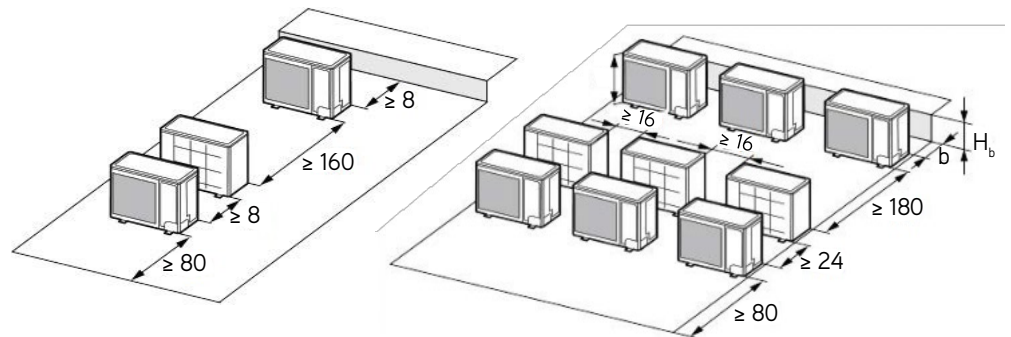

4. When outdoor units are installed one above another.

