



SUBMITTAL DATA

UNIX ECO 19 Seer 60KBTU

Model: TUD60-R32AHEDU/ TU60-R32WGDU

Job Name

Purchaser

Submitted to

Unit Designation

Location

Date

Engineer

For

Schedule No.

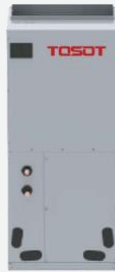

TUD60-R32AHEDU



TU60-R32WGDU

GENERAL FEATURES:

- High Efficiency DC Inverter Technology
- 24VAC Thermostat Compatible
- Zero Lot Line Design
- 8 Speed Fan Motor
- Designed for New Construction or Replacement Market
- Compact and Quiet, as low as 55 dB(A) Side Discharge outdoor unit
- Cooling down to -15°C (5°F)
- Heating down to -30°C (-22°F)
- Coil (Outdoor) Copper Tube/Aluminum Fin with Anti-Corrosion
- Coil Coating (Gold Colored Fin - 1500Hr Salt Spray Rating)
- Coil (Indoor) Copper Tube/Aluminum Fin with Anti-Corrosion
- Coil Coating (Blue Colored Fin - 500Hr Salt Spray Rating)

Americo HVAC Supply LLC



Tel: +1 877-298-7191
Email: info@tosotclima.com
Website: tosotclima.com

1266 San Luis Obispo Ave.
Hayward, CA. 94544



SPECIFICATIONS & FUNCTIONS:

Air Handler		TUD60-R32AHEDU
Power Supply	V~/Phases/Hz	208~230/1/60
Air Flow Volume	CFM	1500
External Static Pressure	W.C.	0.5
External Static Pressure Range	W.C.	0~1
Sound Pressure Level	dB	53
Rated Voltage	V	208/230
Rated Frequency	Hz	60
Phases	-	1
Fuse Current	A	3.15
Circuit Breaker	A	15
Output of Heater	W	6000/9000/12000
MOCP	A	15
Motor Full Load Amp(FLA)	A	6.00
Fan Motor Drive Type	-	Direct-driven
Fan Motor Speed	rpm	1000
Fan Motor Power Output	HP	1
Evaporator Material	-	Inner groove copper tube-Aluminum fin
Evaporator Face Area	sq.ft	5.49
Evaporator Pipe Diameter	inch	0.37
Evaporator Number of Rows	-	4
Evaporator Tube Pitch×Row Pitch	inch	1.0×0.87
Evaporator Fin Pitch	inch	0.071
Evaporator Number of Circuits	-	12
Evaporator L×H×W	inch	16.3×24×3.5
Evaporator Max. Allowable Pressure	MPa	12.7
Air Filter	-	Metal
Air Filter Size L×W/NO.	inch	23.0×20.3/1
Air Filter Size (Thickness)	inch	0.6
Drainage Connection Size	inch	φ1×0.05
Cooling Temperature Range	°F	64.4~89.6
Heating Temperature Range	°F	50~80.6
Refrigerant	-	R32
Dimension of Outline(W×D×H)	inch	24.8×21.26×51.97
Dimension of Package(L×W×H)	inch	27.28×25.98×54.8
Net Weight	lbs	199.5
Gross Weight	lbs	218.3

Product Model		TU60-R32WGDU
Power Supply	VAC/Phase/Hz	208~230/1/60
Cooling Capacity	Btu/h	54000
Heating Capacity	Btu/h	54000
EER	(Btu/h)/W	11.7
COP	(Btu/h)/W	11.6
SEER	-	19
HSPF	-	9.5
Air Flow Volume	CFM	4000
Sound Pressure Level	dB(A)	55
MOCP	A	40
MCA	A	35.5
Compressor Model	-	FTz-SC400AXAB
Compressor Type	-	Inverter Rotary
Compressor Refrigerant Oil Type	-	FW68L
Compressor Refrigerant Oil Charge Volume	L	1.2
Condenser Material	-	Inner Groove Copper Tube-Aluminum fin
Condenser Face Area	sq.ft	11.41
Condenser Pipe Diameter	inch	φ0.28
Condenser Number of Rows	-	3
Condenser Tube Pitch(a)×Row Pitch(b)	inch	0.87×0.75
Condenser Fin Pitch	inch	0.059
Condenser Fins per Inch (FPI)	-	17
Condenser Number of Circuits	-	12
Condenser L×H×W	inch	39.5×36.4×2.3
Cooling Temperature Range	°F	5~118.4
Heating Temperature Range	°F	5~75.2
Defrosting Method	-	Automatic Defrosting
Refrigerant Charge-R32	oz	148.2
Dimension of Outline(W×D×H)	inch	35 7/16×13 3/8×49 5/8
Dimension of Package(L×W×H)	inch	40.7×17.4×55.3
Net Weight	lbs	214
Gross Weight	lbs	236
Connection Pipe Length	ft	24.6
Not Additional Gas Connection Pipe Length	ft	31.2
Connection Pipe Gas Additional Charge	oz/ft	0.215
Line Set Size (Liquid - Gas)	inch	3/8"-3/4"
Connection Pipe Max. Distance H×L	ft	49.2×98.4

FAN PERFORMANCE

Static Pressure (Inches W.C.)	0	0.1	0.15	0.2	0.3	0.4	0.5	0.6	0.7	0.8	0.9	1
Speed 1 (CFM)	1660	1540	1470									
Speed 2 (CFM)	1850	1720	1650	1600								
Speed 3 (CFM)	1920	1800	1730	1650	1480							
Speed 4 (CFM)	2110	2000	1950	1860	1760	1640	1500					
Speed 5 (CFM)	2250	2200	2190	2140	2040	1930	1800	1670	1520			
Speed 6 (CFM)	2260	2220	2200	2170	2090	2010	1910	1760	1650	1550		
Speed 7 (CFM)	2300	2260	2230	2200	2150	2115	2050	1990	1920	1790	1650	1470
Speed 8 (CFM)	2320	2280	2250	2230	2190	2140	2080	2040	2000	1950	1920	1890

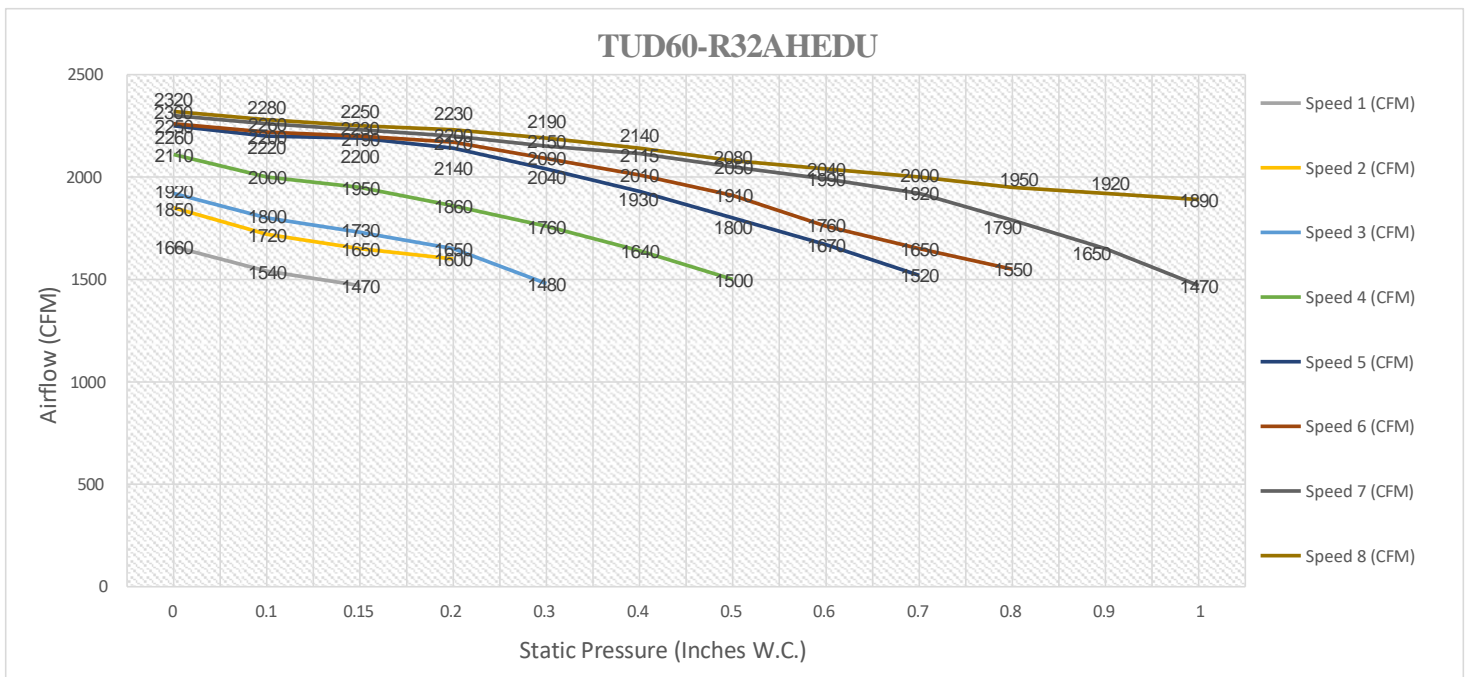

NOTE:

1. Above chart CFM ratings are based on dry coil with factory filter installed.
2. For wet coil CFM ratings, multiply the CFM by 0.96 correction factor.

DIMENSIONS

INDOOR UNIT

Unit: inch

TUD60-R32AHEDU

DIMENSIONS

A	11-5/8
B	20
H	52
W	24-3/4
D	21-1/4

FILTER SIZE

Supplied*	20-3/4 x 20-3/8 x 5/8
Suggested	20-3/4 x 20-3/8 x 1

*Supplied filter is metal mesh

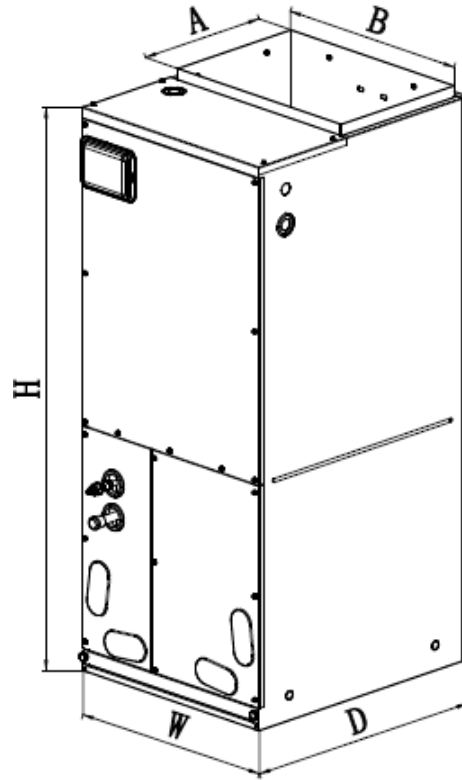

OUTDOOR UNIT

Unit: inch

TU60-R32WGDU

DIMENSIONS

A	39
B	15-13/16
C	37-3/4
D	22-7/16
E	14-9/16
F	38-1/4
G	14-5/8

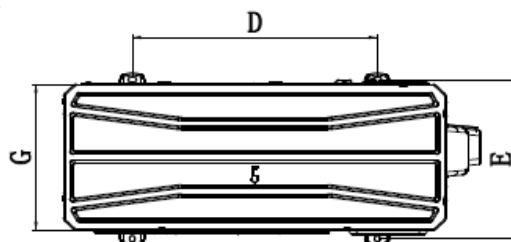
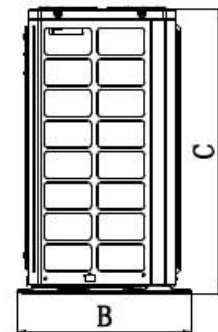
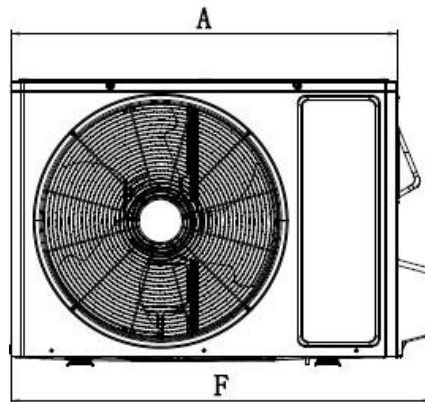

ACCESSORY HEATER AND GENERAL INFORMATION

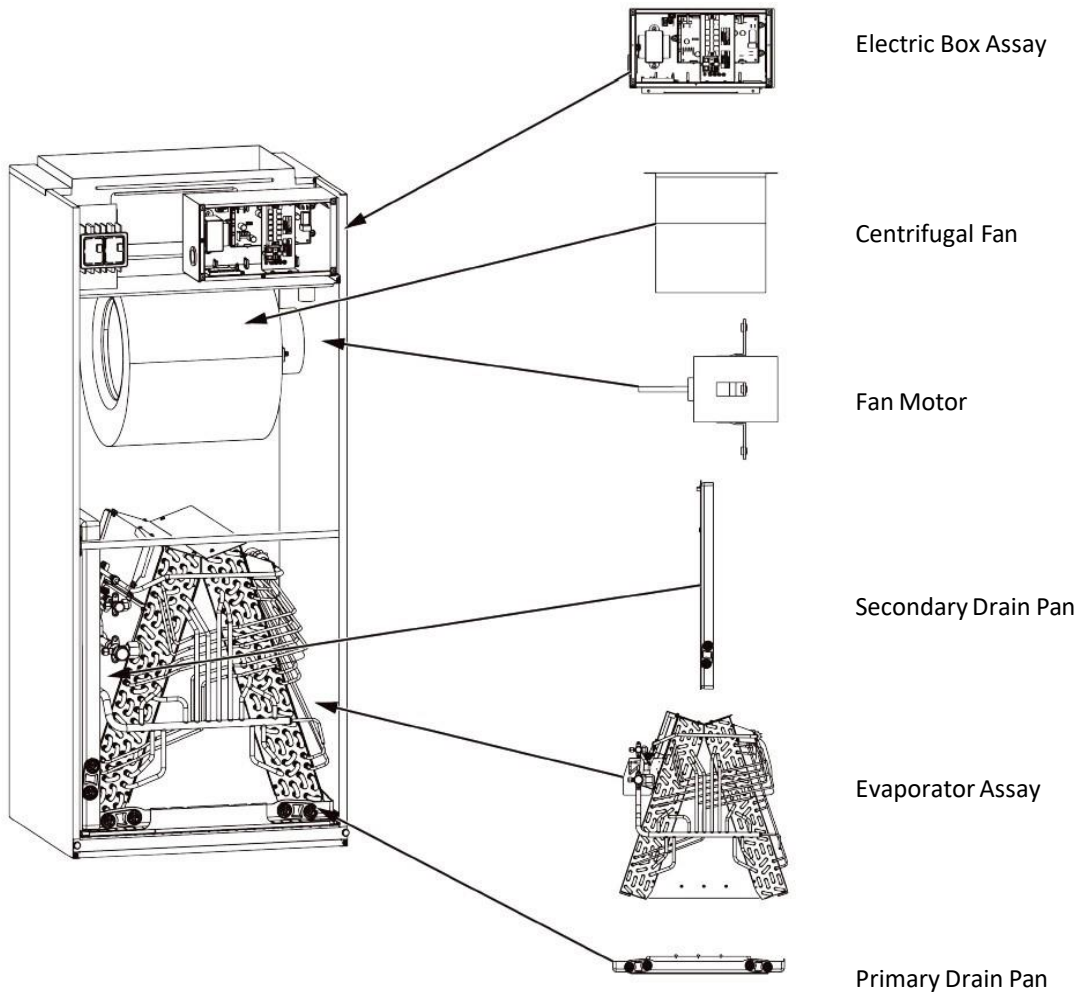

Model	Heat Kit Model	Electric Heat (kW)		Min. Circuit Ampacity (A)		Max Fuse or Breaker (A)								
		208V	230V	208V	230V	208V	230V							
TUD60-R32AHEDU	One Mains Supply													
	ELEMHT16-5KW	3.74	4.6	31	33	35	35							
	ELEMHT16-8KW	6.03	7.36	44	48	45	50							
	ELEMHT16-10KW	7.49	9.2	53	58	60	60							
	Two Mains Supply													
			Power A	Power B	Power A	Power B	Power A	Power B	Power A	Power B	Power A	Power B	Power A	Power B
	ELEMHT16-15KW	7.49	3.74	9.2	4.6	53	23	58	25	60	25	60	60	30
ELEMHT16-20KW	7.49	7.49	9.2	9.2	53	46	58	50	60	50	60	60	60	

CLEARANCES

INDOOR UNIT

Minimum clearance

FRONT

> 24

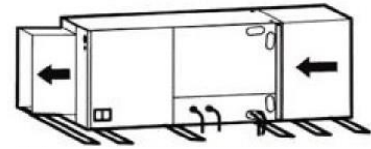
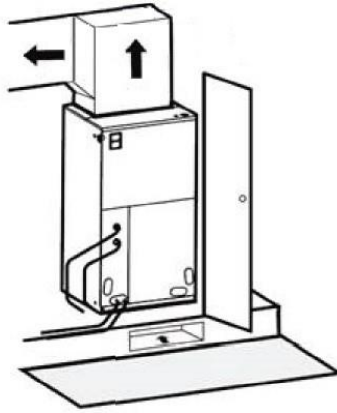

Horizontal Left Configuration - No Modification Needed

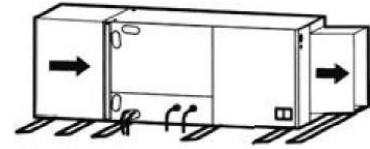

Horizontal Right Configuration - Must Relocate Drain Pan

NOTE:

Allow a minimum of 24" in front of the unit for service clearance. When installing in an area directly over a finished ceiling (such as an attic), an emergency drain pan is required directly under the unit. **See local and state codes for requirements.** When installing this unit in an area that may become wet, elevate the unit with a sturdy, non-porous material. In installations that may lead to physical damage (i.e. a garage) it is advised to install a protective barrier to prevent such damage. This air handler is designed for a complete supply and return ductwork system.

OUTDOOR UNIT

Minimum clearance

NOTE:

Install the Outdoor Unit **2 Inches** Above the Expected Snow Line

1. When one outdoor unit is to be installed.

A - E	H_b H_d H		(in)				
			a	b	c	d	e
B	-	-	-	≥ 4	-	-	-
A, B, C	-	-	≥ 12	≥ 4	≥ 4	-	-
B, E	-	-	-	≥ 4	-	-	≥ 40
A, B, C, E	-	-	≥ 12	≥ 6	≥ 6	-	≥ 40
D	-	-	-	-	-	≥ 40	-
D, E	-	-	-	-	-	≥ 40	≥ 40
B, D	$H_b < H_d$	$H_d < H$	-	≥ 4	-	≥ 40	-
	$H_b > H_d$	$H_d > H$	-	≥ 4	-	≥ 40	-
B, D, E	$H_b < H_d$	$H_d \leq 1/2H$	-	≥ 10	-	≥ 80	≥ 40
		$1/2H < H_d \leq H$	-	≥ 10	-	≥ 80	≥ 40
	$H_b > H_d$	$H_d > H$	Prohibited				
		$H_d \leq 1/2H$	-	≥ 4	-	≥ 80	≥ 40
$H_b > H_d$	$1/2H < H_d \leq H$	-	≥ 8	-	≥ 80	≥ 40	
	$H_d > H$	Prohibited					

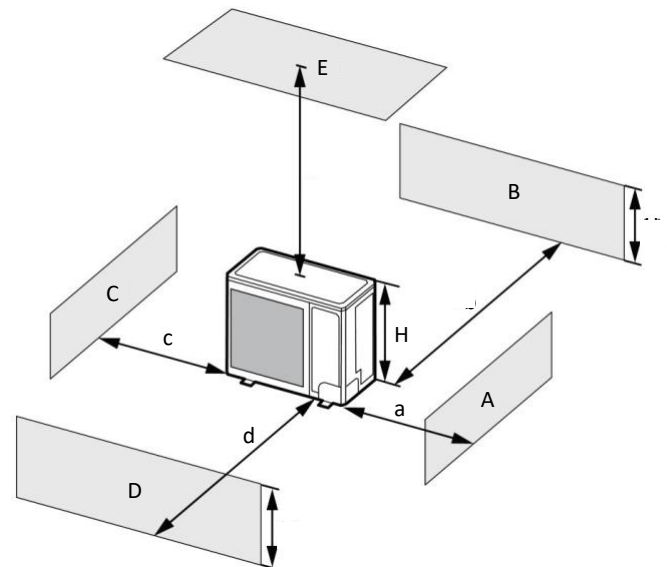

CLEARANCES

2. When two or more outdoor units are to be installed side by side.

A - E	H_b H_d H	a	b	c	d	e	
A, B, C	-	≥ 12	≥ 12	≥ 40	-	-	
A, B, C, E	-	≥ 12	≥ 12	≥ 40	-	≥ 40	
D	-	-	-	-	≥ 80	-	
D, E	-	-	-	-	≥ 80	≥ 40	
B, D	$H_b < H_d$ $H_d > H$	-	≥ 12	-	≥ 80	-	
B, D, E	$H_b > H_d$	$H_d \leq 1/2H$	-	≥ 10	-	≥ 80	
		$1/2H < H_d \leq H$	-	≥ 12	-	≥ 100	
	$H_b < H_d$	$H_d \leq 1/2H$	-	≥ 12	-	≥ 80	≥ 40
		$1/2H < H_d \leq H$	-	≥ 12	-	≥ 100	≥ 40
B, D, E	$H_b > H_d$	$H_d > H$	Prohibited			-	
		$H_d \leq 1/2H$	-	≥ 10	-	≥ 100	≥ 40
	$H_d > H$	Prohibited			-	≥ 40	

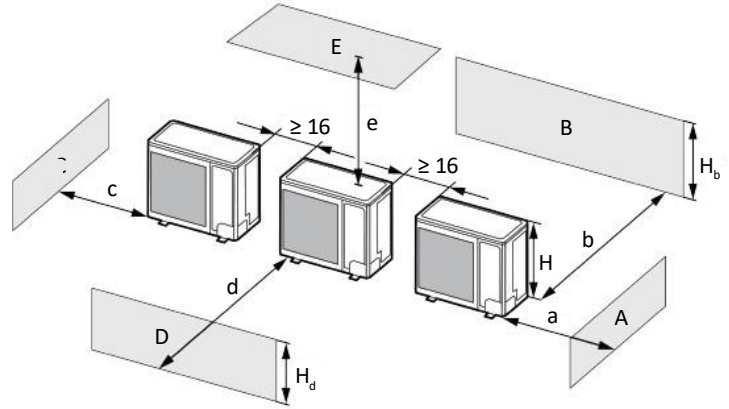

3. When outdoor units are installed in rows.

H_b H_d	(in)
$H_b \leq 1/2H$	$b \leq 10$
$1/2H < H_b \leq H$	$b \leq 12$
$H_b > H_d$	Prohibited

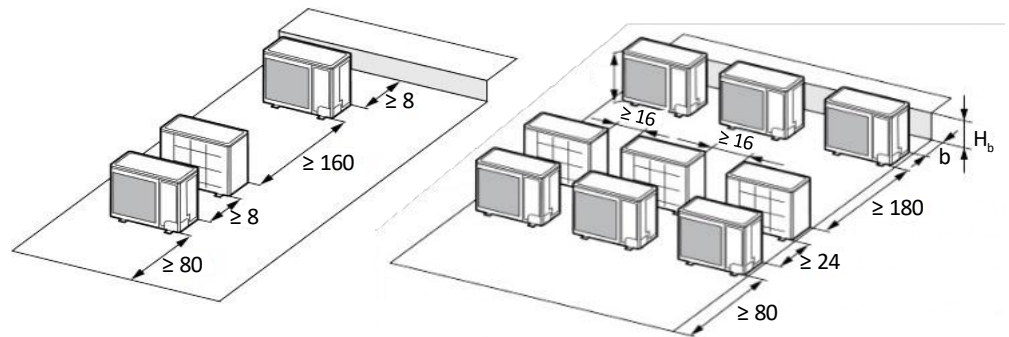

4. When outdoor units are installed one above another.

